

Reaction Torque Sensors

01036

MINI-FLANGE TORQUE SENSOR

This sensor is designed to measure reaction torque when restraining the housing of a test device. Its compact design allows for limited space applications.

SPECIFICATIONS

Capacity..... 26 to 1,000 in-lbs (See chart)
 Overload capacity..... 150% of F.S.
 Output at F.S..... 2.0 mV/V nominal
 Non-linearity..... 0.10% of F.S.
 Hysteresis..... 0.10% of F.S.
 Zero balance..... +/-1% of F.S.
 Compensated temperature..... 70 to 170°F
 Useable temperature..... -65 to +250°F
 Temperature effect on zero..... 0.002% of F.S./°F
 Temperature effect on span..... 0.002% of Rdg./°F
 Bridge resistance..... 700/350 Ohms
 Excitation voltage, maximum..... 20 Vdc
 Material..... Alloy Steel

DIMENSIONS

MODEL	CAPACITY	
	IN LB	NM
01036-260	26	3
01036-520	52	6
01036-012	100	12
01036-022	200	22
01036-052	500	55
01036-013	1000	110

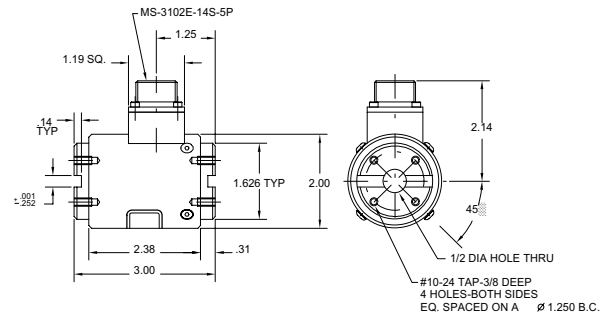

01040

ULTRA-LIGHT TORQUE SENSOR

This low capacity reaction torque sensor is capable of measuring torque with a full scale capacity of 10 in.oz. and a resolution of 0.02 in.oz. The unique sensing element design allows the sensor to carry extraneous loads while being able to accurately measure in the in.oz. range. The small physical size makes it adaptable to many applications where space is limited.



SPECIFICATIONS

Capacity..... 10 & 50 in.oz.
 Overload capacity..... 150% of F.S.
 Output at F.S..... 1.0 mV/V nominal
 Non-linearity..... 0.1% of F.S.
 Hysteresis..... 0.1% of F.S.
 Zero balance..... +/-1% of F.S.
 Compensated temperature..... 70 to 170°F
 Useable temperature..... -65 to +250°F
 Temperature effect on zero..... 0.002% of F.S./°F
 Temperature effect on span..... 0.002% of Rdg./°F
 Bridge resistance..... 350 Ohms
 Excitation voltage, maximum..... 15 Vdc
 Material..... Aluminum

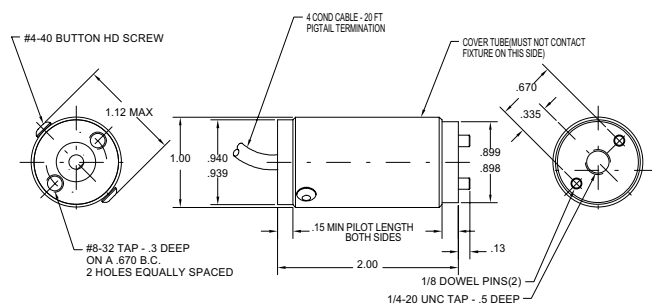

Distributed by: Spare S.r.l.
 Via Carlo Spagnolo, 4 - 27057 Varzi - Pavia - Italy
 tel. +39-0383-54.51.51 - fax: +39-0383-54.50.51
<http://www.spare.it> - <http://www.spareonweb.com>
 e-mail: sales@spare.it